

# REDUCING ENERGY CONSUMPTION OF WATER REUSE FOR LEADING BREWERY IN MEXICO



**LOCATION**

Mexico

**ESTIMATED ENERGY SAVINGS**  
112.3 MWh annually

**CUSTOMER**  
LEADING BREWERY IN  
MEXICO

**CAPACITY**  
2,592 m<sup>3</sup>/day

**ESTIMATED COST SAVINGS**  
\$11,000 USD/year

## THE CHALLENGE

North central Mexico is home to one of the largest breweries in the world – which produces millions of liters of beer annually. As Mexico's beverage industry developed, it became critical to produce energy-efficient water for brewing that didn't interfere with the local water supply.

With rising water scarcity, recycling wastewater poses a viable solution for water conservation. In line with sustainability goals, the brewery implemented a coupled membrane wastewater treatment system with hollow fiber ultrafiltration as pretreatment and brackish water low-pressure reverse osmosis (RO). In wastewater reuse systems with multiple stages, membrane fouling resulting from imbalanced flux can be a barrier to optimal system operation. For this reason, the plant needed a solution to address fouling and increase energy efficiency.

## THE SOLUTION

The plant designers chose to integrate Energy Recovery's turbocharger to lower the system's energy consumption and optimize flux across the first and second stages. The brewery collaborated with a leading membrane supplier and Energy Recovery, Inc. to design its reuse system. This innovative wastewater treatment plant was optimized using computational fluid dynamics, utilizing highly selective membranes and Energy Recovery's efficient turbocharger – a cost-effective solution.

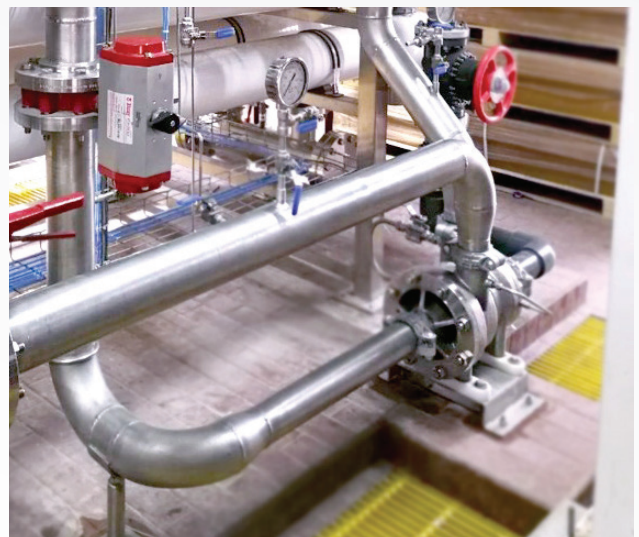

The turbocharger was integrated between the first and second stages to transfer the pressure energy from the second stage's reject stream to the second stage's feed stream. It acts as a booster pump between the stages, resulting in the same flux-balancing benefits, such as reduced membrane fouling.

The turbocharger's advantage is that it is energized entirely by the brine flow and does not require external motors, mechanical seals, or controls.

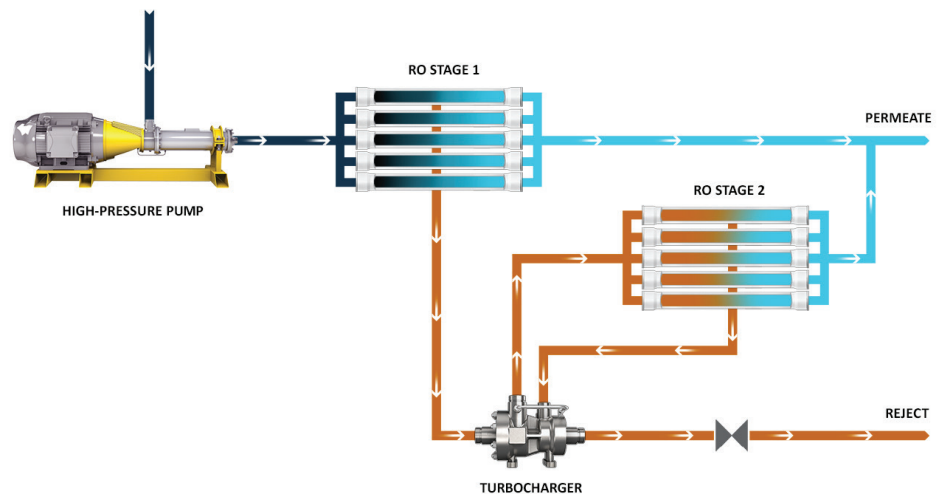

**“Energy Recovery's turbochargers save energy and help balance the flux between stages, extending the life of the membrane system and ultimately resulting in increased uptime. The rate of fouling and replacement also decreases, leading to fewer maintenance issues and increased operational savings.”**

— Jose Luna, Consultant

## THE RESULT

By implementing Energy Recovery's turbocharger, the wastewater reuse system reduced energy consumption by 18%, lowering operational energy costs by approximately \$11,000 USD annually.

Using the turbocharger provides the added benefit of eliminating the need for an interstage booster pump running on electricity, allowing the facility to cut down operational costs.

The resulting interstage flux balance also provided benefits such as increased membrane life, reduced chemical consumption, and lowered clean-in-place (CIP) frequency, leading to low RO system downtime. With reduced overall power requirements, the entire wastewater treatment system with energy recovery devices achieved a 10% reduction in water consumption, saving over 6.4 million cubic meters of water annually from underground sources.

To learn more, visit [energyrecovery.com](https://energyrecovery.com)



©2024 Energy Recovery  
November 2024